

ROBINSON SHUTTER ORDER FORM

ISSUE DATE 14/05/13

SFX 118000



101 Central Park Drive, Private Bag 93 113, Henderson, Auckland, New Zealand, Tel +64 9 837 2350 Fax + 64 9 837 2354

CUSTOMER	
CONTACT NAME	
PHONE	FAX
ORDER #	JOB #
DATE OF ORDER	DELIVERY DATE REQ. (EX STRUCTURFLEX)
DELIVERY ADDRESS	
OTHER INFORMATION	

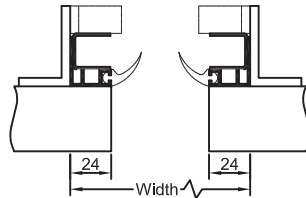
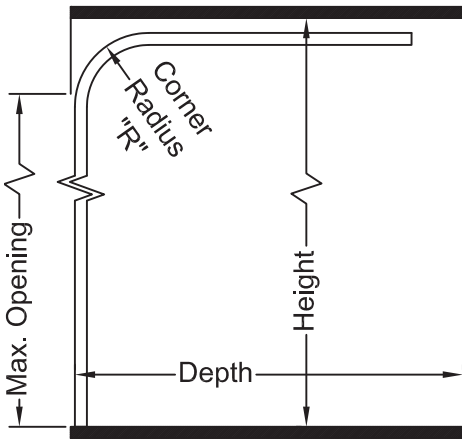
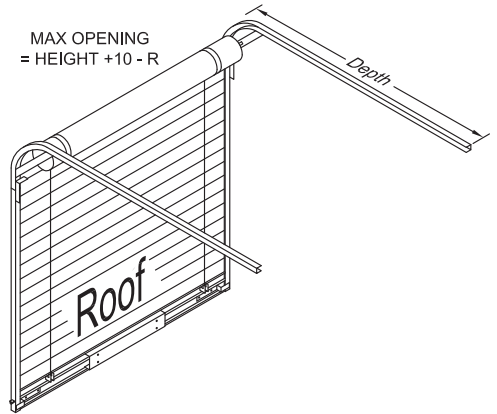

OPTION A

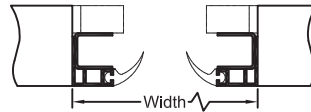

OPTION B

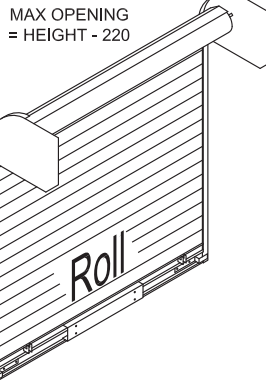
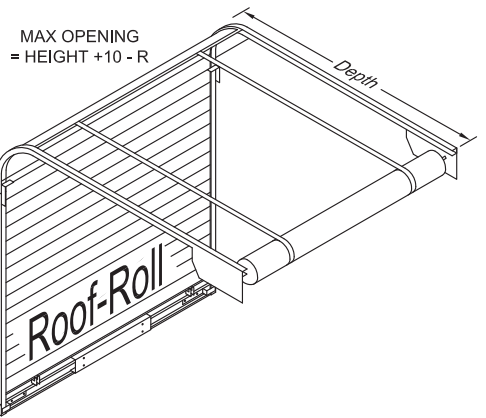

ACTUAL OPENING DIMENSIONS						
DIMENSIONS	W	mm	H	mm	D	mm
WHEN MEASURING PLEASE NOTE	Record actual opening dimensions – width and height. All allowances for clearances are made by Structurflex. If Cavity Depth is less than door height please record above.					
	75mm radius is a helper wheel 100 and 160mm radii are rolled channels					
	Recommended maximum height for Roll type door 2.0m Recommended maximum height for all other types 2.4m					

DOOR TYPE									
	ROOF		ROOF-ROLL			ROLL		LOCKER	
OPERATOR DRUM	Yes	No	Yes			Yes		No	
SLAT TYPE (mm)	34	57	34	57		34	57	34	57
R – CORNER RADIUS (mm)	75*	100	160	75*	100	160	N/A	75*	100
LOCK TYPE	Slamlock		Slamlock			Slamlock		Slamlock	
	Lift Bar*		Lift Bar*			Lift Bar*		Lift Bar*	
	Finger Pull		Finger Pull			Finger Pull		Finger Pull	
SIDE SEAL	Yes	No	Yes	No	Yes	No	Yes	No	
FINISH	Mill		Mill			Mill		Mill	
	PC White		PC White			PC White		PC White	
	Custom		Custom			Custom		Custom	
NOTE	*To be used with 34 series slates only								
SIGNATURE	<input type="checkbox"/> I approve the use of the details for product manufacture								

